

Read this instruction carefully. See hardware and furniture part list for guidance. Be sure all parts are complete, before you assemble. Place all wooden furniture parts on a clean and flat soft surface to prevent from being scratched. Follow the figure to start assembling.

**CAUTIONS :** 1. Do not FULLY - TIGHTEN the nut or nut bolt until all nut or bolt is ready assembled.  
 2. Do not OVER - TIGHTEN the nut or bolt to avoid causing damages to the thread.  
 3. Keep all hardware parts out of reach of children.

**NOTE :** THE LIST AND QUANTITY SHOWN ARE FOR 1 UNIT ASSEMBLY.  
 Tool needed : Screwdriver (not provider).

PART LIST		
ITEM	DESCRIPTION	QTY
A	HEADBOARD	1 PC
B	FOOTBOARD	1 PC
C	SIDE RAIL	2 PCS
D	CENTER RAIL	1 PC
E	CENTER SUPPORT LEG	3 PCS
F	CENTER SUPPORT	2 PCS
G	BED SLAT	24 PCS
H	HEADBOARD LEG	2 PCS
I	FOOTBOARD LEG	2 PCS

HARDWARE LIST		
ITEM	DESCRIPTION	QTY
1	JCBC BOLT M6 x 50mm	8 PCS
2	WOOD SCREW M3.5 x 16mm	8 PCS
3	WOOD SCREW M4 x 20mm	2 PCS
4	M4 ALLEN KEY (BALL SHAPE)	1 PC
5	M5 ALLEN KEY (BALL SHAPE)	1 PC
6	BED SLAT SIDE FITTER	24 PCS
7	BED SLAT CENTER FITTER	12 PCS

## STEP 1

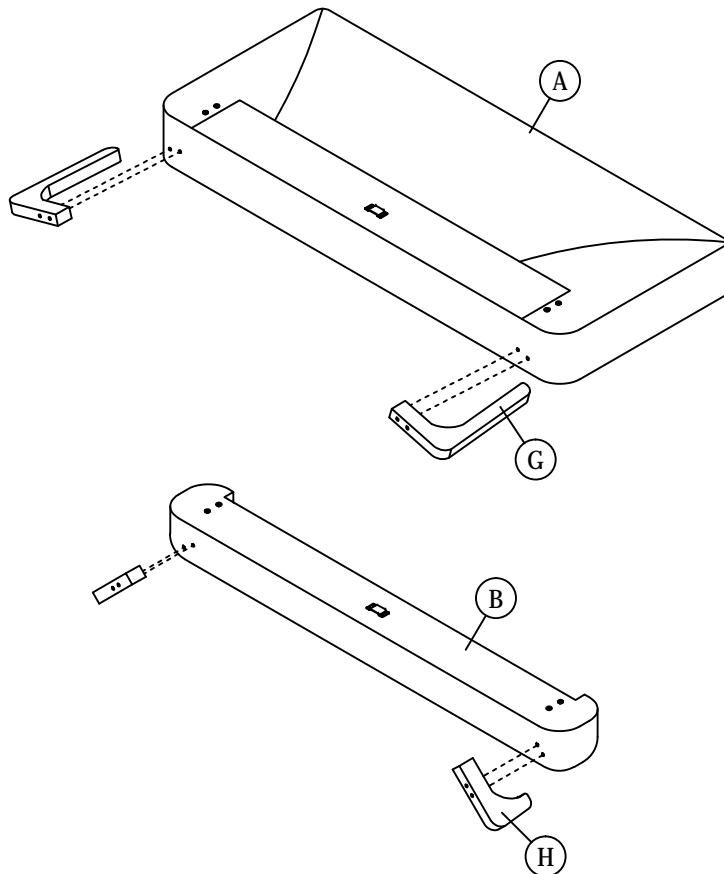

## STEP 2

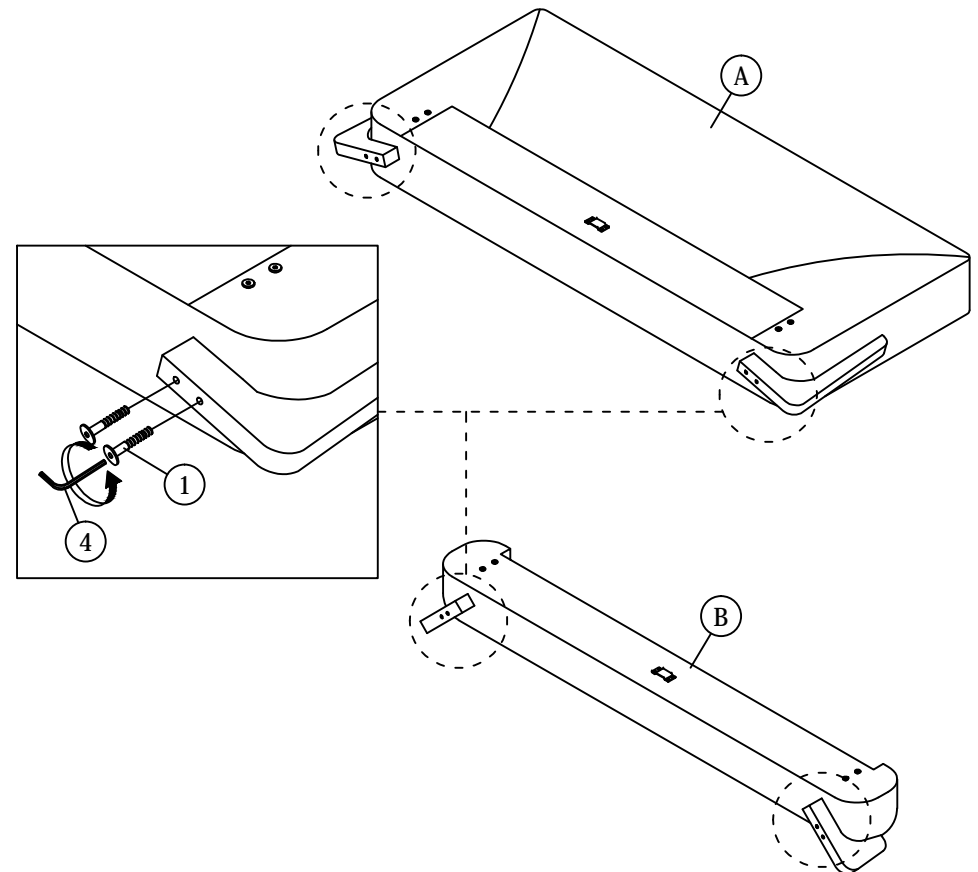

# ASSEMBLY INSTRUCTIONS

## STEP 3

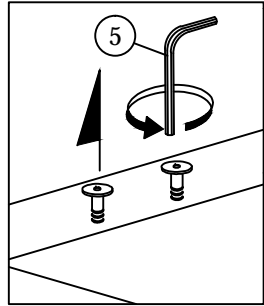

Loosen the pre-inserted bolt on the headboard and footboard using Allen key ball shape (5).

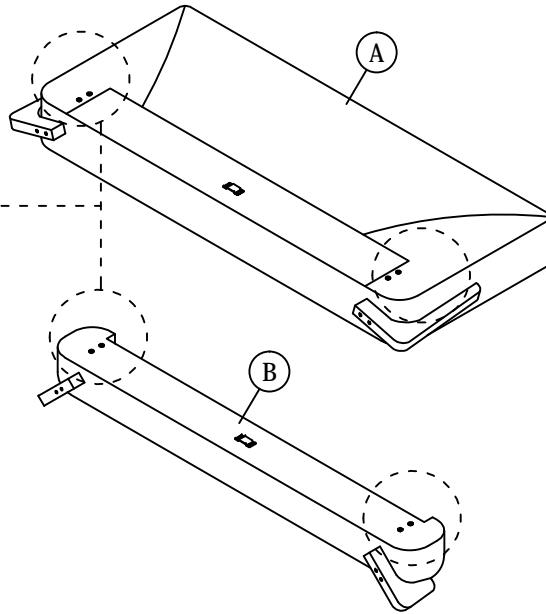

## STEP 4

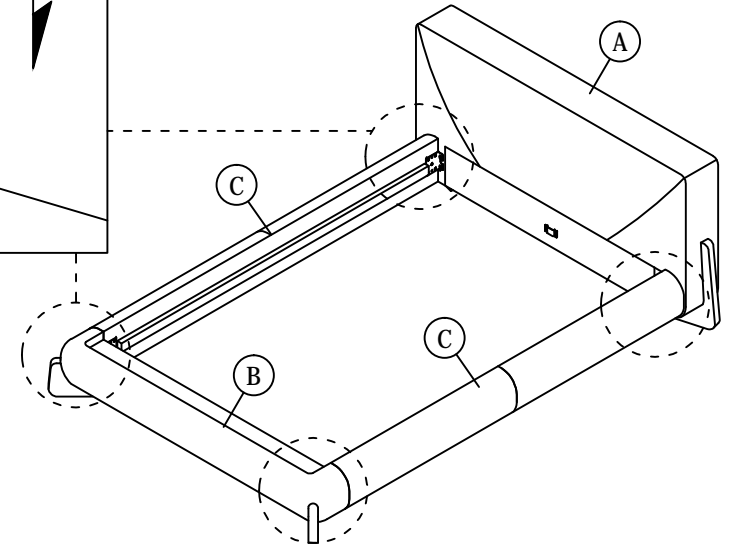
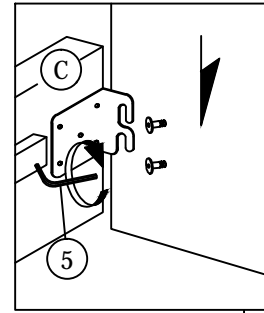

## STEP 5

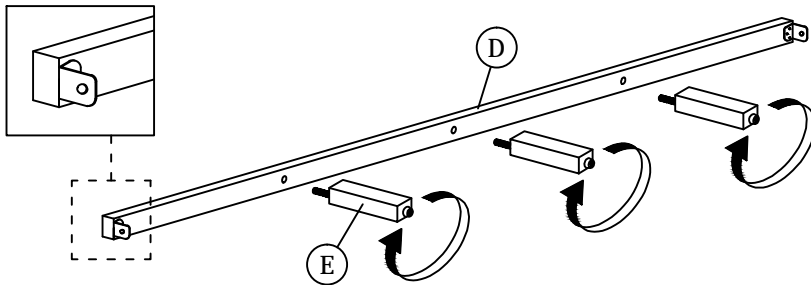

## STEP 6

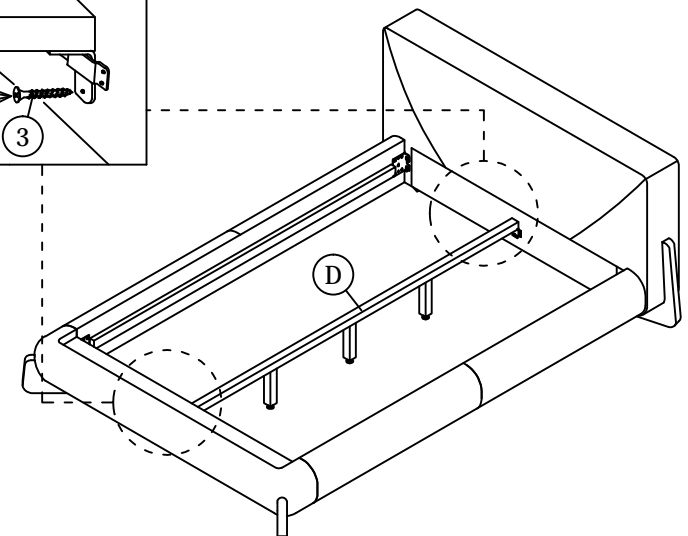
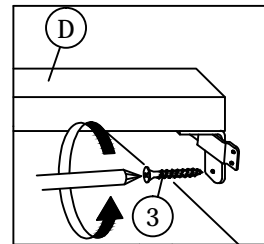

# ASSEMBLY INSTRUCTIONS

## STEP 7

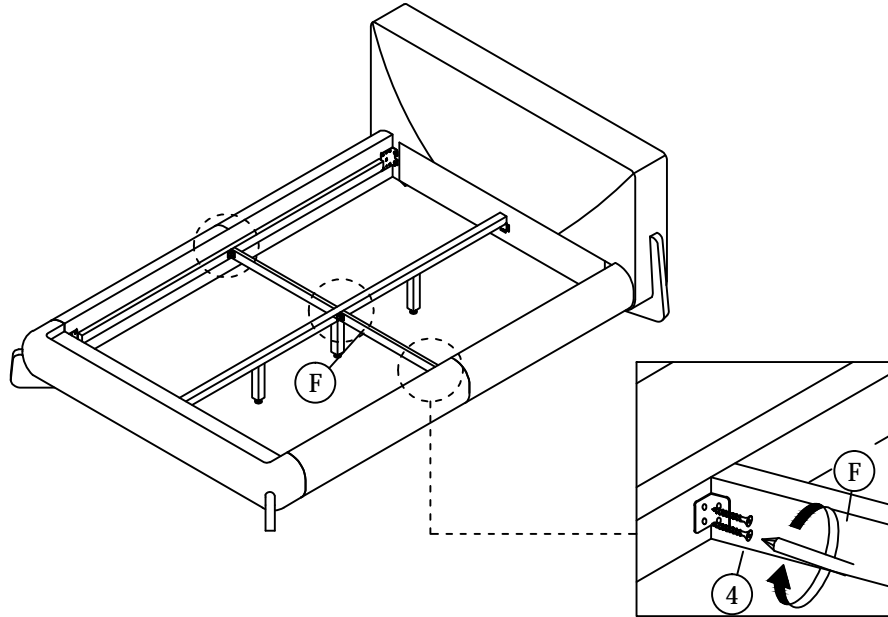

## STEP 8

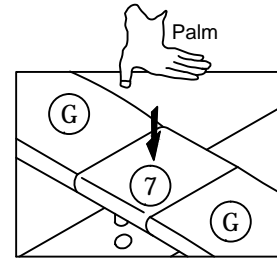

### STEP 8.1

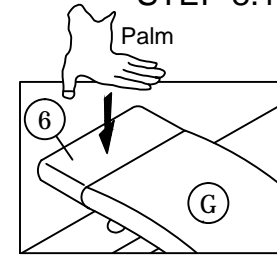

### STEP 8.2

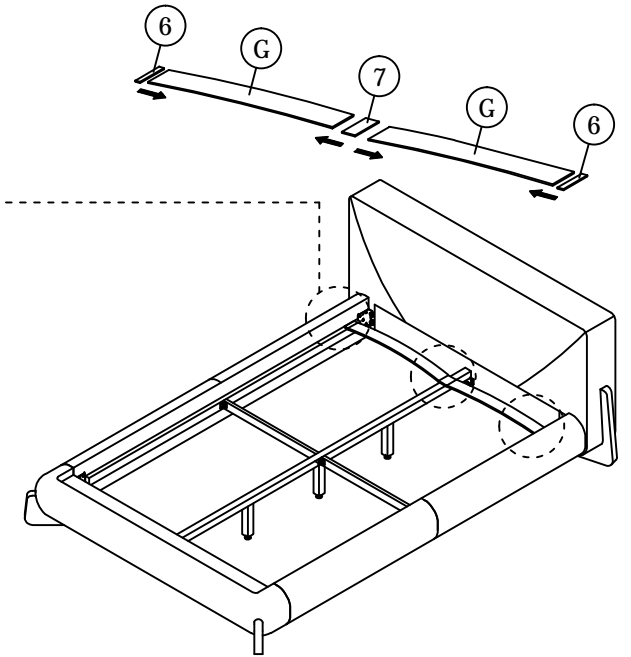

## STEP 9

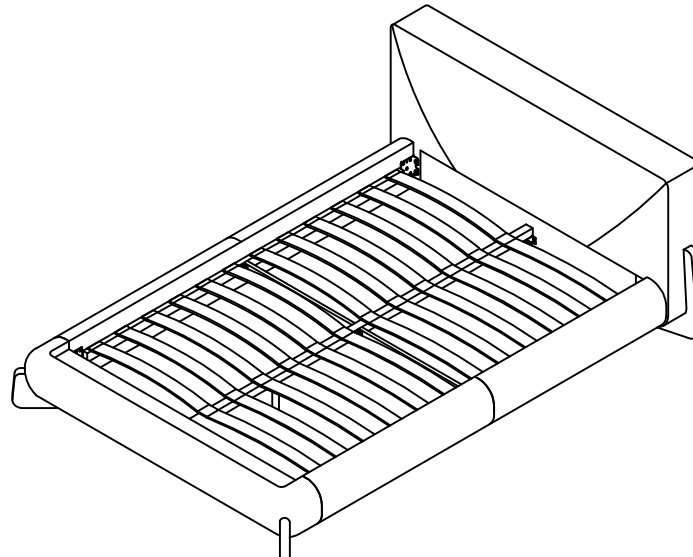

**\* When moving the bed position, the center support legs must be adjust to be straight to avoid any broken problem.**